



Proposed Freud Sanitary Pump Station
05/20/24

Agenda

- 💧 Where Does the Water Go?
- 💧 Background
- 💧 Project Goals & Design
- 💧 Project Advantages
- 💧 Project Graphics
 - 💧 Overview
 - 💧 Landscape Plan
 - 💧 Street View - Northwest
 - 💧 Street View - Northeast
 - 💧 Street View - West
 - 💧 3D Model Views
- 💧 Traffic Control
- 💧 Project Schedule
- 💧 Questions



Where Does the Water Go?



[Video - Where Does the Water Go?](#)

Project Background

Conners Pump Station

- Constructed in 1929
- Sanitary pump station has 4 pumps; total capacity 215 MGD
- Storm pump station has 8 pumps (500 cfs each); total capacity 4,000 cfs (2,584 MGD)
- Fills an Olympic-size swimming pool (660,000 gallons) in 22 seconds
- 4 (2MW) backup generators that can support 2 pumps. Equivalence of powering 2,860 homes.

Freud Pump Station

- Constructed in 1955
- Sanitary pump station has 2 pumps; total capacity 36 MGD
- Storm pump station has 8 pumps (450 cfs each); total capacity 3,500 cfs (2,325 MGD)
- Fills an Olympic-size swimming pool (660,000 gallons) in 25 seconds
- 4 (2MW) backup generators that can support 2 pumps. Equivalence of powering 2,860 homes.

Conner Creek CSO Facility

- Treatment rate of 13,260 cfs (8,570 MGD)
- Retention volume of 62 MG
- Treats/captures >4 BG on average annually

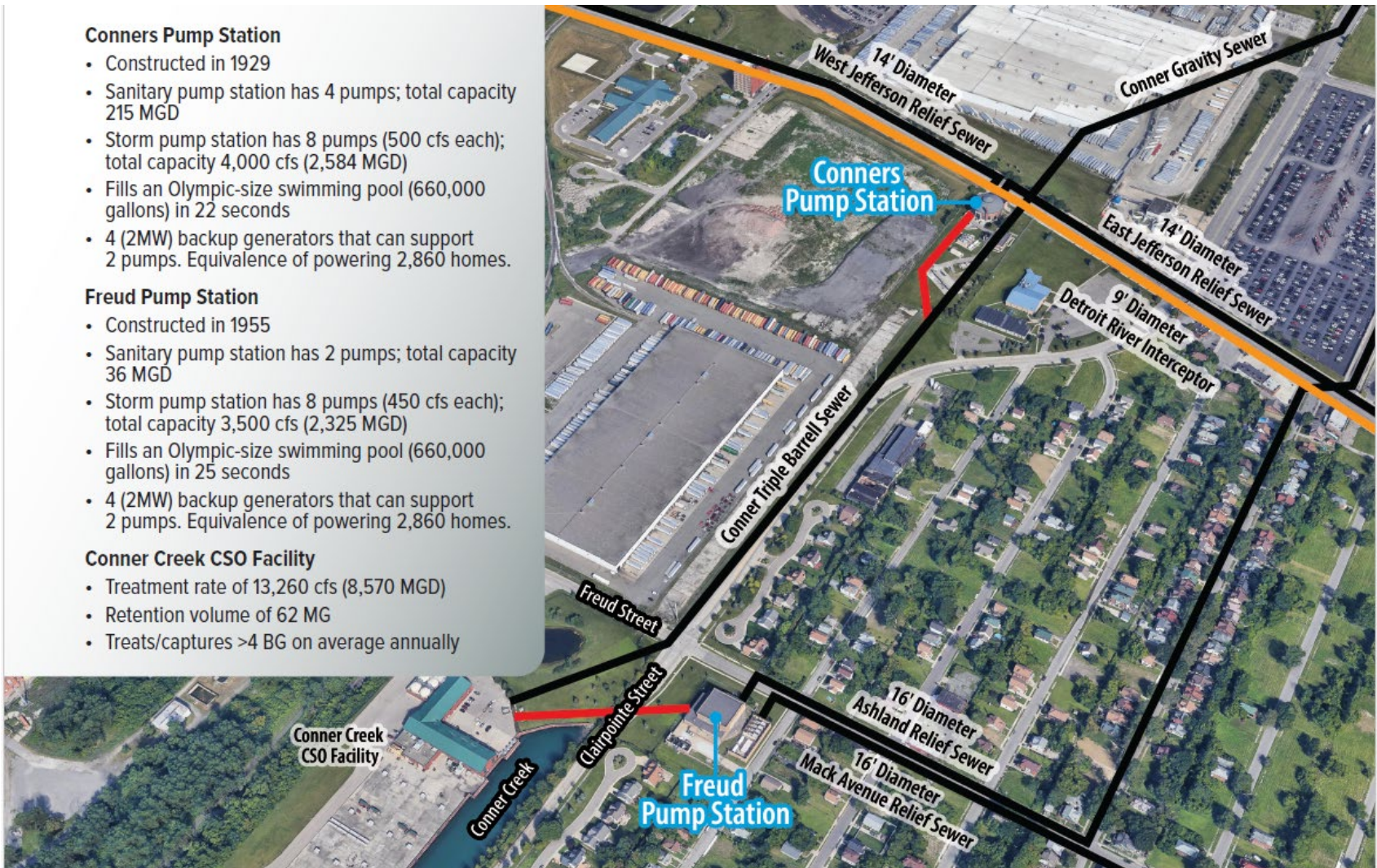

Project Background

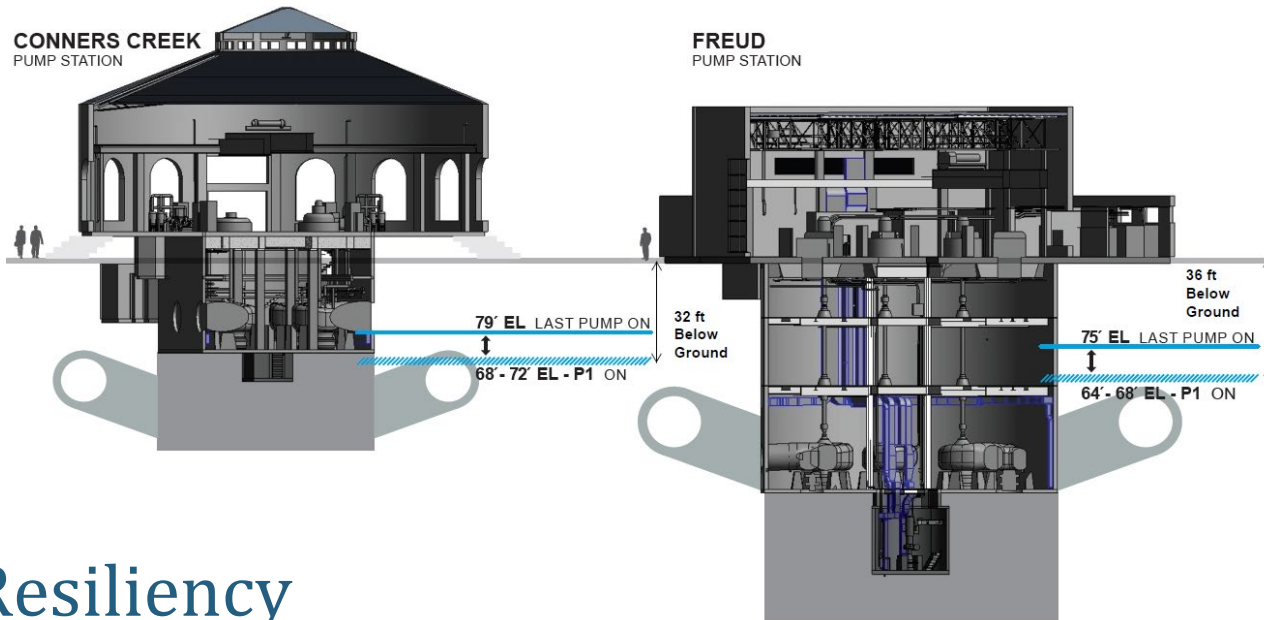

💧 Resiliency

💧 Power Monitoring and Reliability

💧 System access for routine Maintenance

💧 Mechanical upgrades

Project Goals & Design

- Protect the Health, Safety, & Welfare of Residents
- Improve the Reliability of Freud Storm Pump Station
 - Rehabilitation
 - Isolation
 - Cleaning
 - Inspection
 - Maintenance
- Maximize GLWA ability to keep sewer water levels low during rain events
- Help prevent basement backups



Project Advantages

- ◆ Improved Reliability of Storm & Sanitary Systems
- ◆ Traffic Calming
- ◆ Enhanced Landscaping Plan
- ◆ Bioswales & Rain Gardens
- ◆ Doubling of Mature Trees
- ◆ Abandoned Structure Removal
- ◆ Improved Drainage at Freud Storm Pump Station

Overview

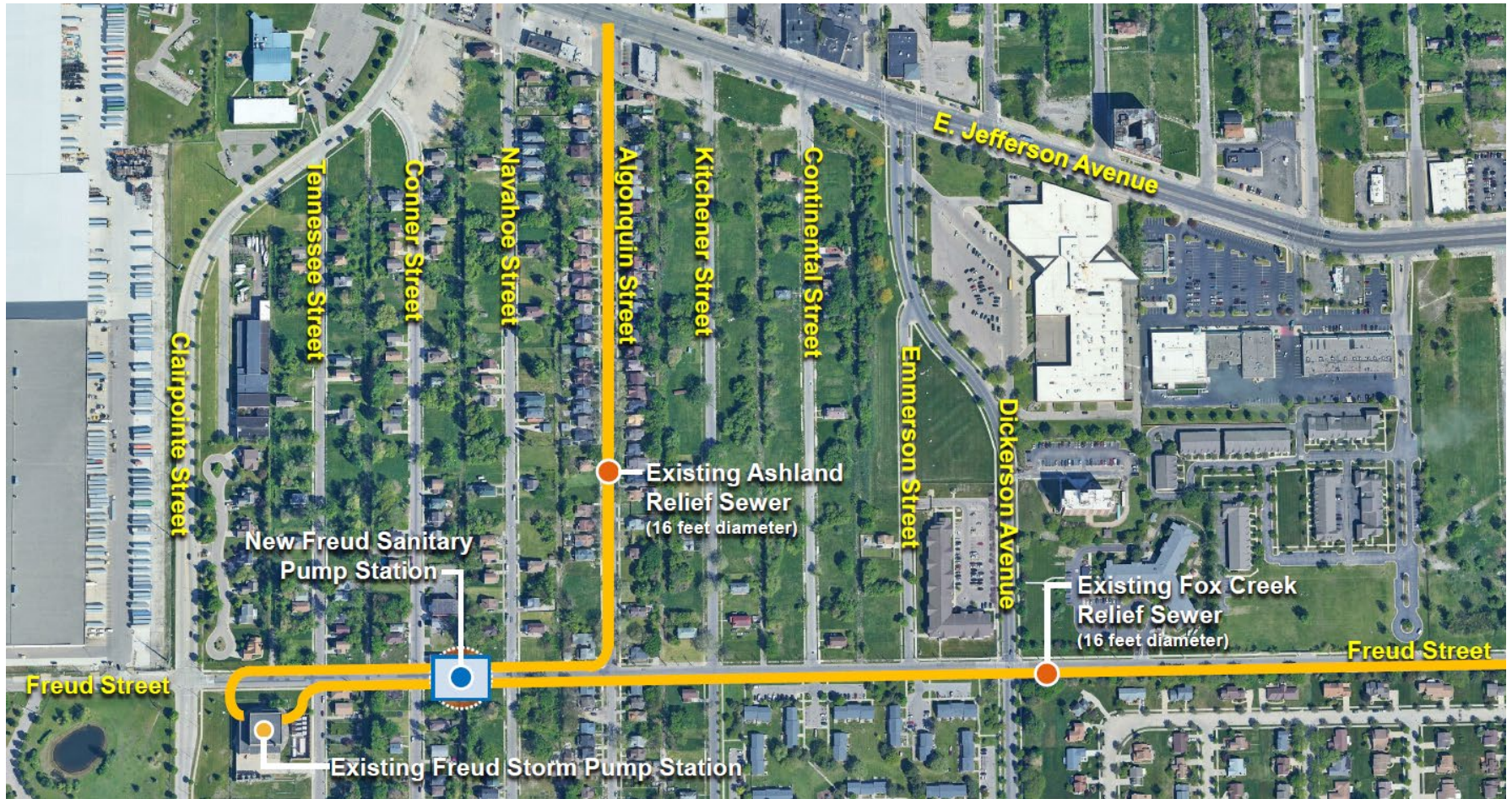

Landscape Plan

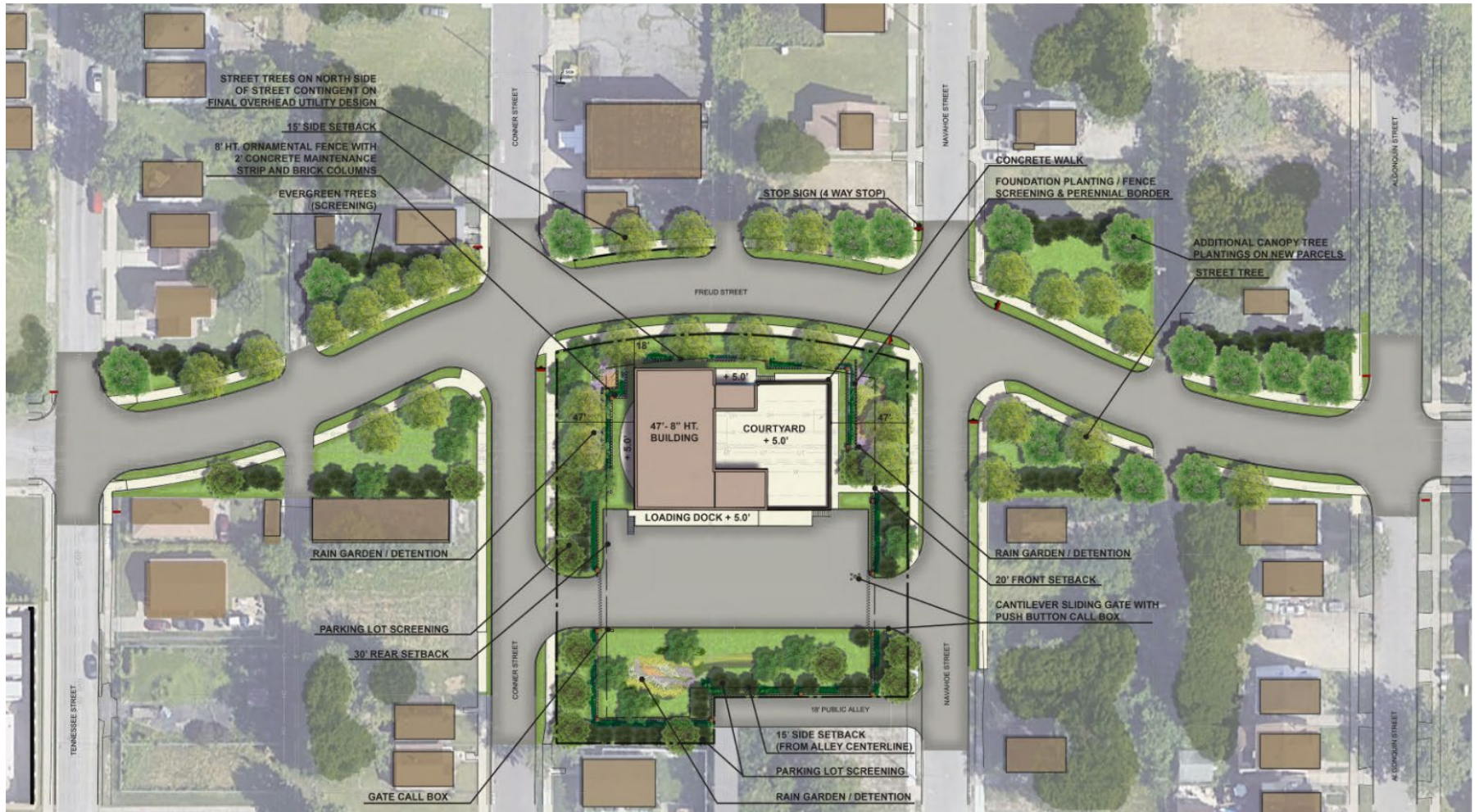

Street View - Northeast



Street View - Northwest



Street View - West



3D Model Views

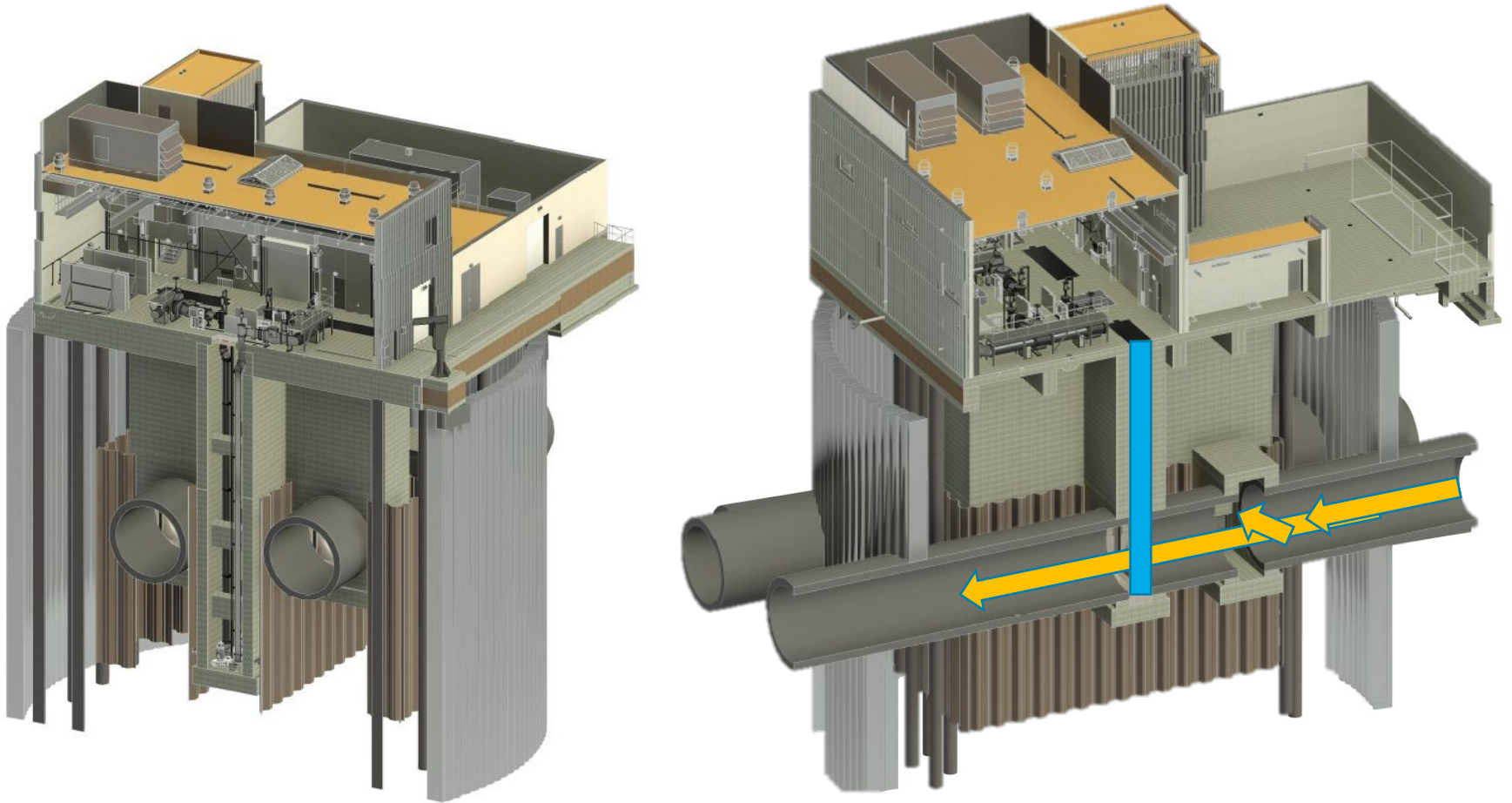

Traffic Control



Project Schedule

◆ Contractor Notice to Proceed	Q2 2024
◆ Abandoned Structure Removal	Q2 2024
◆ Contractor Site Mobilization	Q4 2024
◆ Project Completion	Q2 2028

*Project Schedule is in development more details to follow.

Questions

